

12MB600

High Output Midbass Ferrite Transducer

Key Features

- 101 dB SPL 1W / 1m average sensitivity
- 75 mm (3 in) Interleaved Sandwich Voice coil (ISV)
- 450 W continuous pink noise power handling
- Weather protected cone and plates for outdoor usage
- Excellent transient response
- Ideal for compact two way and multiway systems
- Improved heat dissipation via unique basket design



General Description

The 12MB600 is a high sensitivity (101dB 1W/1m) midbass driver with high power handling capabilities. It can be used as either a bass/mid driver in compact 2-way reflex enclosures or as a direct radiating or horn loaded, dedicated midrange driver, in multi-way touring and fixed installation concert and arena systems.

The curvilinear paper cone is made with a special high strength wood pulp designed to achieve the best possible linearity within its intended frequency range and to control bell-mode resonances around the cone circumference. The cone is carried by a multiroll suspension formed from a linen-like material which is more resistant to aging and fatigue than traditional materials.

The 75 mm state-of-the-art voice coil is similar to those fitted to our top-of-the-range 18" and 15" models but it is wound with aluminum wire. It employs our Interleaved Sandwich Voice coil (ISV) technology in which a high strength fiberglass former carries windings on both the outer and inner surfaces to achieve a mass balanced coil. This results in an extremely linear motor assembly with a reduced tendency for eccentric behavior when driven hard.

The magnetic structure has been optimized using our in-house FEACAD resource which has maximized the flux density in the voice coil gap.

Voice coil cooling has been achieved by incorporating airways between the chassis back plate and the top plate of the magnet which allow heated air from the voice coil and gap to be channeled away and dissipated by the chassis basket. The cone is the result of a meticulous 3D CAD software design exercise within the Eighteen Sound R&D facility. Due to the increasing use of high power audio systems at outdoor events or in marine environments, the ability to perform properly under inclement weather conditions is a feature in Eighteen Sound's philosophy. Hence, an exclusive treatment is applied to the cone giving it water repellent properties. In addition, another special treatment is applied to the top and back plates making the transducer far more resistant to the corrosive effects of salts and oxidation.

0221285210 8 Ohm
0221245210 4 Ohm

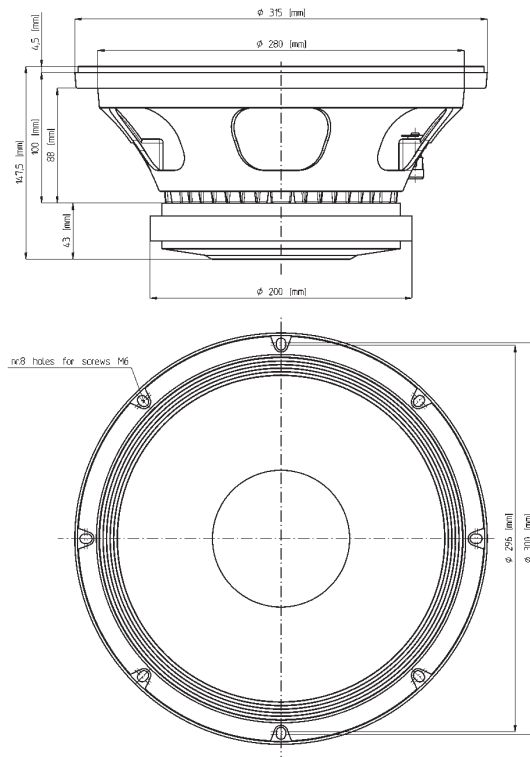

FERRITE LF-MB-MF TRANSDUCERS

12MB600

High Output Midbass Ferrite Transducer

GENERAL SPECIFICATIONS

NOMINAL DIAMETER	300 mm (12 in)
RATED IMPEDANCE	8 Ohm
CONTINUOUS PINK NOISE (1)	450 W
CONTINUOUS POWER (2)	300 W
PROGRAM POWER (3)	600 W
PEAK POWER (4)	1200 W
SENSITIVITY (5)	101 dB
FREQUENCY RANGE (6)	58 ÷ 5000 Hz
POWER COMPRESSION @-10DB (7)	(30 W) 0,5 dB
POWER COMPRESSION @-3DB	(150 W) 1,6 dB
POWER COMPRESSION @FULL POWER	(300 W) 3,0 dB
MAX RECOMM. FREQUENCY	2200 Hz
RECOMM. ENCLOSURE VOLUME	30 ÷ 80 lt. (1,06 ÷ 2,83 cuft)
MINIMUM IMPEDANCE	6,5 Ohm at 25°C
MAX PEAK TO PEAK EXCURSION	22 mm (0,87 in)
VOICE COIL DIAMETER	75 mm (2,95 in)
VOICE COIL WINDING MATERIAL	aluminum
POLARITY	positive voltage on red terminal gives forward cone motion

THIELE SMALL PARAMETERS (8)

Fs	44 Hz
Re	5 Ohm
Sd	0,0531 sq.mt. (82,31 sq.in.)
Qms	3,9
Qes	0,19
Qts	0,18
Vas	115 lt. (4,06 cuft)
Mms	43 gr. (0,09 lb)
BL	18 Tm
Linear Mathematical Xmax (9)	± 4,5 mm (± 0,18 in)
Le (1kHz)	1,32 mH
Ref. Efficiency 1W@1m (half space)	99,2 dB

MOUNTING INFORMATION

Overall diameter	315 mm (12,4 in)
N. of mounting holes	8
Mounting holes diameter	7,15 mm (0,28 in)
Bolt circle diameter	296 - 300 mm (11,65 - 11,8 in)
Front mount baffle cutout ø	282 mm (11,1 in)
Rear mount baffle cutout ø	282 mm (11,1 in)
Total depth	147,5 mm (5,82 in)
Flange and gasket thickness	16,5 mm (0,65 in)
Net weight	8,0 kg (17,66 lb)
Shipping weight	8,8 kg (19,43 lb)
CardBoard Packaging dimensions	332 x 332 x 184 mm (13,07 x 13,07 x 7,24 in)

FREQUENCY RESPONSE CURVE OF 12MB600 MADE ON 50 LIT. ENCLOSURE TUNED 60HZ IN FREE FIELD (4PI) ENVIRONMENT. ENCLOSURE CLOSES THE REAR OF THE DRIVER. THE THIN LINE REPRESENTS 45 DEG. OFF AXIS FREQUENCY RESPONSE

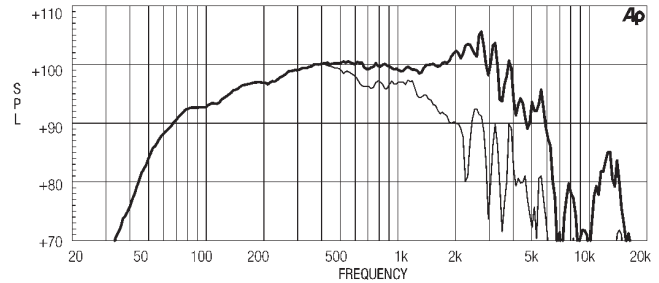

FREE AIR IMPEDANCE MAGNITUDE CURVE

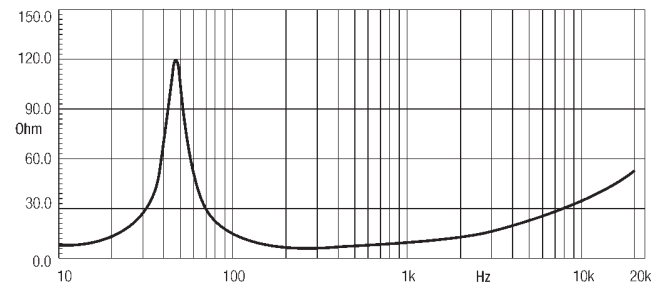

NOTES

- (1) AES standard
- (2) Continuous power rating is measured in 50 lit enclosure tuned 60Hz using a 60 - 2000Hz band limited pink noise test signal applied continuously for 2 hours.
- (3) Program power rating is measured as for 2 above but 50% duty cycle.
- (4) The peak power rating is based on a 6dB crest factor above the continuous power rating and represents the maximum permitted instantaneous peak power level over a maximum period of 10ms which will be withstood by the loudspeaker without damage.
- (5) Sensitivity represents the averaged value of acoustic output as measured on the forward central axis of cone, at distance 1m from the baffle panel, when connected to 2,83V sine wave test signal swept between 500Hz and 2500Hz with the test specimen mounted in the same enclosure as given for 2 above.
- (6) Frequency range is given as the band of frequencies delineated by the lower and upper limits where the output level drops by 10 dB below the rated sensitivity in half space environment.
- (7) Power compression represents the loss of sensitivity for the specified power, measured from 50-500 Hz, after a 5 min pink noise preconditioning test at the specified power.
- (8) Thiele - Small parameters are measured after the test specimen has been conditioned by 450 W AES power and represent the expected long term parameters after a short period of use.
- (9) Linear Mat. Xmax is calculated as; $(Hvc-Hg)/2 + Hg/4$ where Hvc is the coil depth and Hg is the gap depth.

Eighteen Sound engages in research and product improvement. New materials and design refinements can be introduced into existing products without notice.