

XG14

Line Array Source

Key Features

- 1.4" entry line-array source
- 10° vertical coverage angle
- Transmission line acoustical design minimizes internal reflections and acoustical losses
- Throat shape optimized for lowering air distortion
- Compact size for high arrayability
- Die-cast aluminum construction
- Offered in combination with ND1480A or NSD1424BTN compression drivers

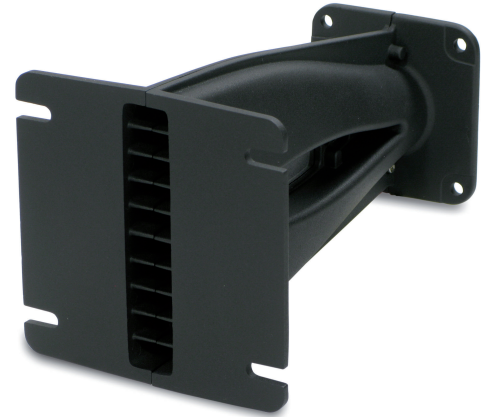

General Description

The XG14 is a 1.4 inch throat entry line-array waveguide. The specific transmission line acoustical design minimizes internal reflections and acoustical losses, while throat shape has been optimized for lowering air distortion.

The XG14 has been optimised for obtaining a 10° vertical dispersion angle, while the horizontal coverage angle could vary from 80° to 120° depending on the specific cabinet design.

The waveguide has been developed to obtain optimum performances when it will coupled with 1.4 inch exit Eighteen Sound high frequency compression drivers.

042XG14H00

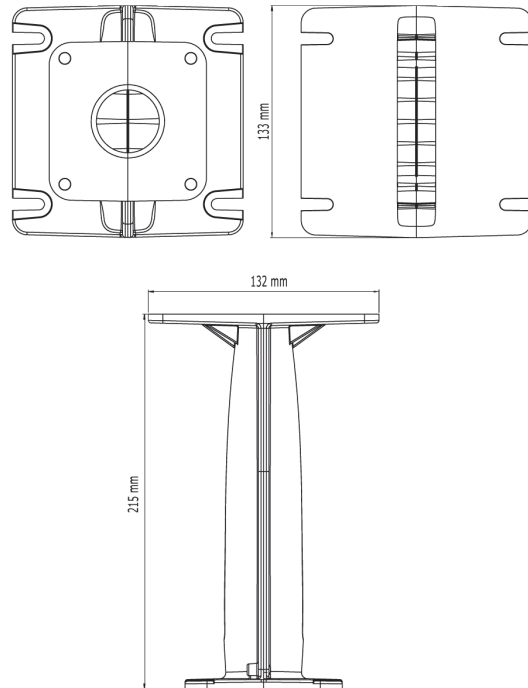

LINE ARRAY SOURCES

GENERAL SPECIFICATIONS

THROAT DIAMETER	35,5 mm (1,4 in)
HORIZONTAL COVERAGE (-6DB)	100° nominal
VERTICAL COVERAGE (-6 DB)	10° nominal
USABLE FREQUENCY RANGE	Above 800 Hz
SENSITIVITY (ON AXIS) (1)	111 dB
FREQUENCY RANGE	500 Hz ÷ 18KHz
MATERIAL	Die-cast aluminum

MOUNTING INFORMATIONS

Flange Height	126 mm (5 in)
Mouth Width	133 mm (5.25 in)
Depth	215 mm (8.45 in)
Flange Mounting	4 screws ø 6
Net weight	1 kg (2.10 lb)
Gross weight	1,3 Kg (2.73 lb)

HORIZONTAL POLAR DIRECTIVITY MAP

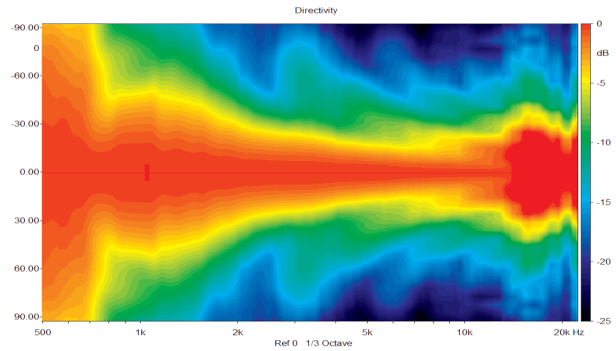

VERTICAL POLAR DIRECTIVITY MAP

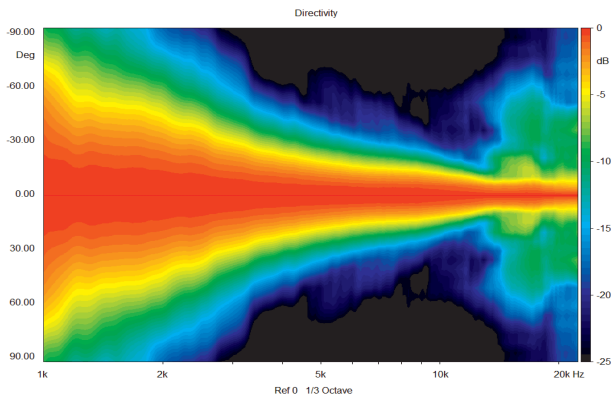

NOTES

(1) Sensitivity is measured at 1W input on ND1480A rated impedance at 1m on axis from the mouth of the line array source, averaged between 1kHz and 4 kHz.

Eighteen Sound engages in research and product improvement. New materials and design refinements can be introduced into existing products without notice.